

# Pump Chamber 1250 Gallon Monolithic

**Atlas Concrete Products**  
**1-800-774-111**

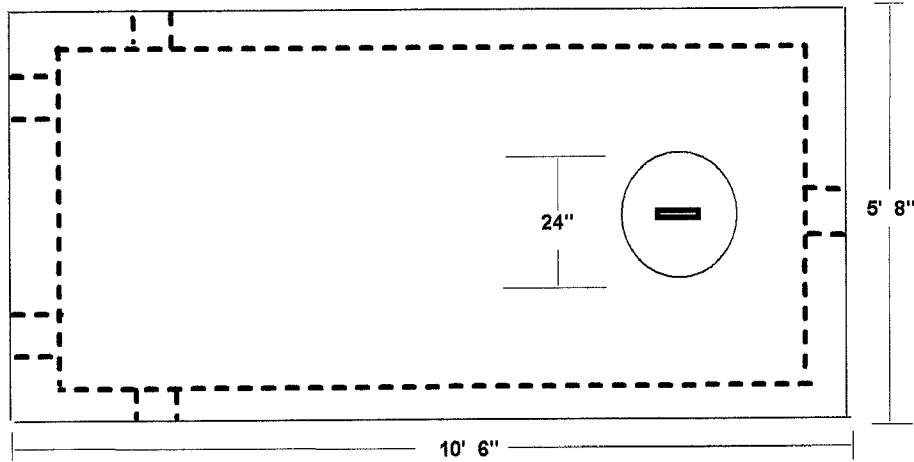

**All tank inlets and outlet are sealed with a gasket**

**ASTM C-1227 Compliant**

**Maximum earth cover 4 feet**

**Concrete compressive strength 4,000 psi @ 28 days**

**12" risers and 36' cover available**

